

Transient Voltage Suppression Diodes: SMF Series

SMD Type 200 W



■ Features

1. Low profile and space saving
2. For surface mounted applications
3. RoHS compliant
4. Reliable low cost construction utilizing molded plastic technique
5. Glass passivated chip
6. Both bi-directional and uni-directional devices are available
7. Typical IR less than 1 μ A above 13V
8. Fast response time
9. Excellent clamping capacity
10. 200W peak pulse power capability with a 10/1000 μ s waveform, repetition rate (duty cycle): 0.01%

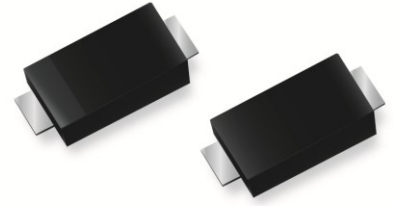

■ Recommended Applications

1. Telecommunication
2. Computer
3. Industrial device
4. Consumer electronic device

■ Mechanical Data

1. Case: SOD-123S, molded plastic meets UL flammability rating 94V-0
2. Terminal: Solder plated, solderable per MIL-STD-750 Method 2026.
3. Polarity: The band denotes cathode (Note: no polarity indicator for bi-directional devices)

■ Part Number Code

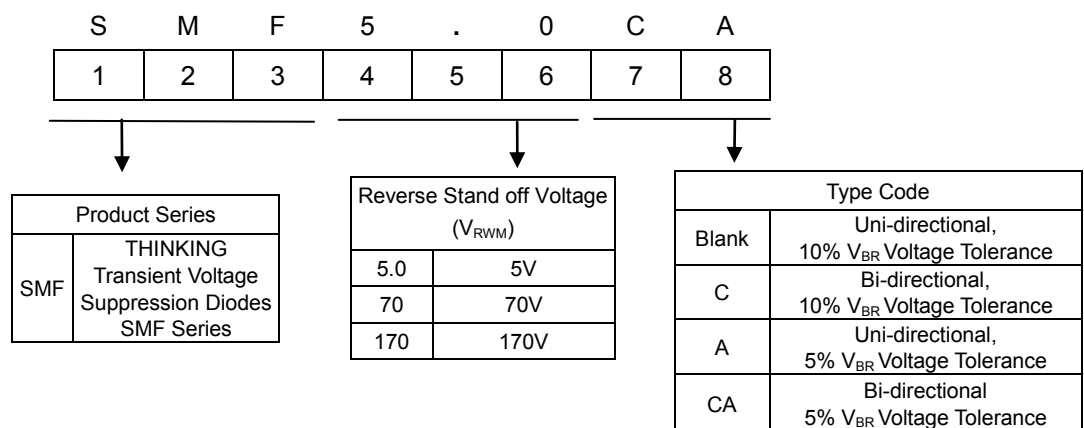

Transient Voltage Suppression Diodes: SMF Series

SMD Type 200 W



Structures and Dimensions

SOD-123

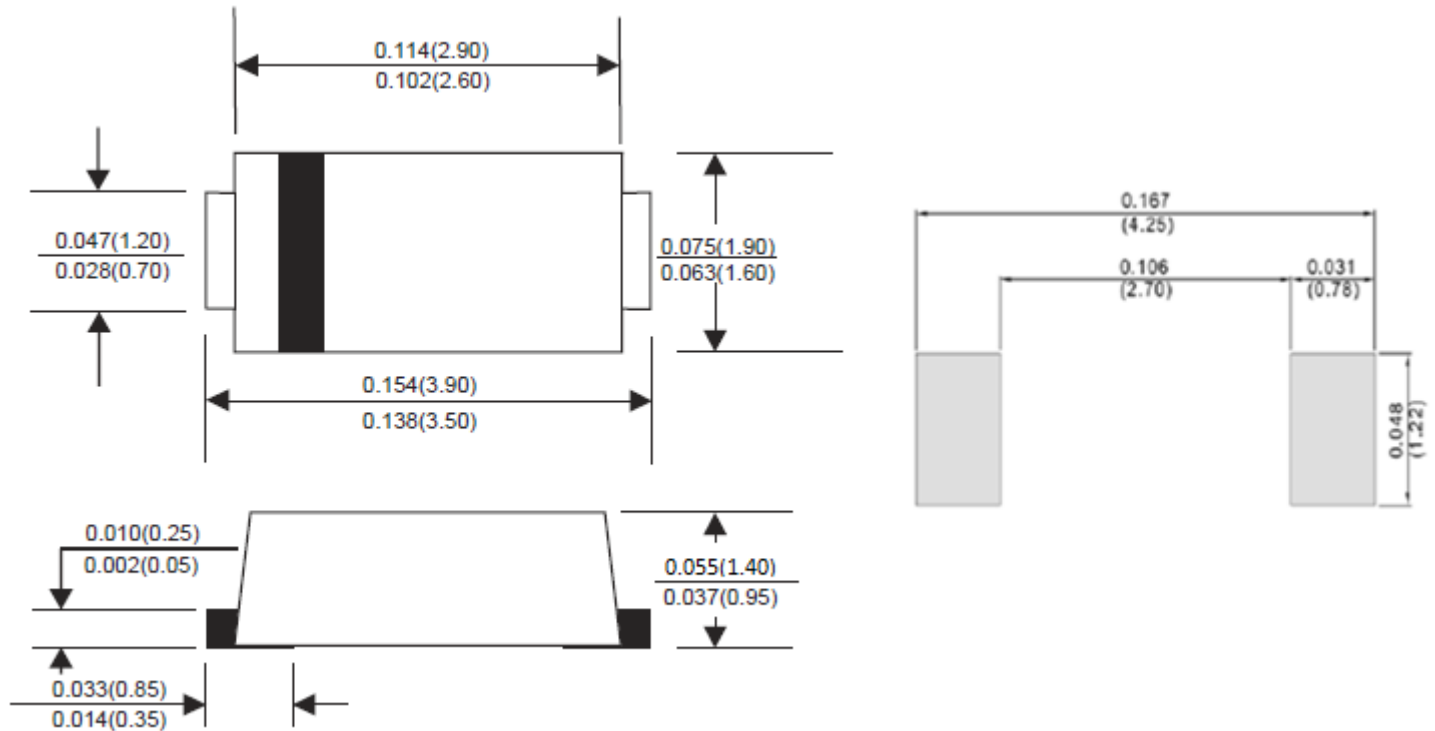

Dimensions: inches (millimeters)

Maximum Rating ($T_A=25^\circ\text{C}$ unless otherwise noted)

Parameter	Symbol	Value	Unit
Peak pulse power dissipation at $T_A=25^\circ\text{C}$ by 10/1000 μs waveform fig.1 (Note 1, Fig.4)	P_{PPM}	200	W
Peak pulse current of on 10/1000 μs waveform.(Note1, Fig.5)	I_{PPM}	See Table	A
Peak forward surge current, 8.3ms single half sine wave on rated load (Note 2, Fig2)	I_{FSM}	20	A
Steady state power dissipation at $T_L =75^\circ\text{C}$ (Fig.3).	$P_{\text{M(AV)}}$	0.4	W
Operating junction and storage temperature range	T_J, T_{STG}	-55~+150	$^\circ\text{C}$

Note: 1. Please refer to Fig. 5 for non-repetitive current pulse, and Fig. 1 for derated above $T_A = 25^\circ\text{C}$

2. 8.3ms single half sine-wave, or square wave that has a maximum of 4 pulses per minute.

Transient Voltage Suppression Diodes: SMF Series



SMD Type 200 W

■ Electrical Characteristics ($T_A=25^\circ\text{C}$ unless otherwise noted)

Part No. (Uni)	Part No. (Bi)	Reverse Stand off Voltage	Breakage Voltage V_{BR} @ I_T		Test Current	Maximum Clamping Voltage V_C @ I_{pp}	Maximum Peak Pulse Current	Maximum Reverse Leakage I_R @ V_{RWM}	Marking Code	
			V_{RWM} (V)	Min(V)					Max(V)	I_T (mA)
SMF5.0A	SMF5.0CA	5.0	6.40	7.00	10	9.2	21.7	400	FE.	KE.
SMF6.0A	SMF6.0CA	6.0	6.67	7.37	10	10.3	19.4	400	FG.	KG.
SMF6.5A	SMF6.5CA	6.5	7.22	7.98	10	11.2	17.9	250	FK.	KK.
SMF7.0A	SMF7.0CA	7.0	7.78	8.60	10	12.0	16.7	100	FM.	KM.
SMF7.5A	SMF7.5CA	7.5	8.33	9.21	1	12.9	15.5	50	FP.	KP.
SMF8.0A	SMF8.0CA	8.0	8.89	9.83	1	13.6	14.7	25	FR.	KR.
SMF8.5A	SMF8.5CA	8.5	9.44	10.4	1	14.4	13.9	10	FT.	KT.
SMF9.0A	SMF9.0CA	9.0	10.0	11.1	1	15.4	13.0	5	FV.	KV.
SMF10A	SMF10CA	10	11.1	12.3	1	17.0	11.8	2.5	FX.	KX.
SMF11A	SMF11CA	11	12.2	13.5	1	18.2	11.0	2.5	FZ.	KZ.
SMF12A	SMF12CA	12	13.3	14.7	1	19.9	10.1	2.5	HE.	LE.
SMF13A	SMF13CA	13	14.4	15.9	1	21.5	9.3	1	HG.	LG.
SMF14A	SMF14CA	14	15.6	17.2	1	23.2	8.6	1	HK.	LK.
SMF15A	SMF15CA	15	16.7	18.5	1	24.4	8.2	1	HM.	LM.
SMF16A	SMF16CA	16	17.8	19.7	1	26.0	7.7	1	HP.	LP.
SMF17A	SMF17CA	17	18.9	20.9	1	27.6	7.2	1	HR.	LR.
SMF18A	SMF18CA	18	20.0	22.1	1	29.2	6.8	1	HT.	LT.
SMF20A	SMF20CA	20	22.2	24.5	1	32.4	6.2	1	HV.	LV.
SMF22A	SMF22CA	22	24.4	26.9	1	35.5	5.6	1	HX.	LX.
SMF24A	SMF24CA	24	26.7	29.5	1	38.9	5.1	1	HZ.	LZ.
SMF26A	SMF26CA	26	28.9	31.9	1	42.1	4.8	1	JE.	ME.
SMF28A	SMF28CA	28	31.1	34.4	1	45.4	4.4	1	JG.	MG.
SMF30A	SMF30CA	30	33.3	36.8	1	48.4	4.1	1	JK.	MK.
SMF33A	SMF33CA	33	36.7	40.6	1	53.3	3.8	1	JM.	MM.
SMF36A	SMF36CA	36	40.0	44.2	1	58.1	3.4	1	JP.	MP.
SMF40A	SMF40CA	40	44.4	49.1	1	64.5	3.1	1	JR.	MR.
SMF43A	SMF43CA	43	47.8	52.8	1	69.4	2.9	1	JT.	MT.
SMF45A	SMF45CA	45	50.0	55.3	1	72.7	2.8	1	JV.	MV.
SMF48A	SMF48CA	48	53.3	58.9	1	77.4	2.6	1	JX.	MX.

Note: For bidirectional type having V_{RWM} of 10 volts and under, the I_R limit is doubled.

Transient Voltage Suppression Diodes: SMF Series

SMD Type 200 W



■ Electrical Characteristics ($T_A=25^\circ\text{C}$ unless otherwise noted)

Part No. (Uni)	Part No. (Bi)	Reverse Stand off Voltage	Breakage Voltage V_{BR} @ I_T		Test Current	Maximum Clamping Voltage V_C @ I_{pp}	Maximum Peak Pulse Current	Maximum Reverse Leakage I_R @ V_{RWM}	Marking Code	
			V_{RWM} (V)	Min(V)					Max(V)	I_T (mA)
SMF51A	SMF51CA	51	56.7	62.7	1	82.4	2.4	1	JZ.	MZ.
SMF54A	SMF54CA	54	60.0	66.3	1	87.1	2.3	1	XE.	NE.
SMF58A	SMF58CA	58	64.4	71.2	1	93.6	2.1	1	XG.	NG.
SMF60A	SMF60CA	60	66.7	73.7	1	96.8	1.8	1	XK.	NK.
SMF64A	SMF64CA	64	71.1	78.6	1	103	1.7	1	XM.	NM.
SMF70A	SMF70CA	70	77.8	86.0	1	113	1.5	1	XP.	NP.
SMF75A	SMF75CA	75	83.3	92.1	1	121	1.4	1	XR.	NR.
SMF78A	SMF78CA	78	86.7	95.8	1	126	1.4	1	XT.	NT.
SMF85A	SMF85CA	85	94.4	104	1	137	1.3	1	XV.	NV.
SMF90A	SMF90CA	90	100	111	1	146	1.2	1	XX.	NX.
SMF100A	SMF100CA	100	111	123	1	162	1.1	1	XZ.	NZ.
SMF110A	SMF110CA	110	122	135	1	177	1.0	1	TE.	PE.
SMF120A	SMF120CA	120	133	147	1	193	0.9	1	TG.	PG.
SMF130A	SMF130CA	130	144	159	1	209	0.8	1	TK.	PK.
SMF150A	SMF150CA	150	167	185	1	243	0.7	1	TM.	PM.
SMF160A	SMF160CA	160	178	197	1	259	0.7	1	TP.	PP.
SMF170A	SMF170CA	170	189	209	1	275	0.6	1	TR.	PR.

Note: For bidirectional type having V_{RWM} of 10 volts and under, the I_R limit is doubled.

Transient Voltage Suppression Diodes: SMF Series

SMD Type 200 W



■ Rate and Characteristic Curve ($T_A=25^{\circ}\text{C}$ unless otherwise noted)

FIG.1 - PULSE DERATING CURVE

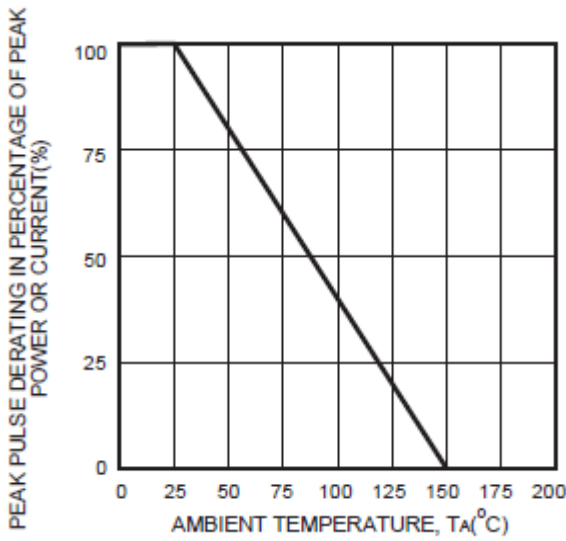

FIG.2- MAX. NON-REPETITIVE SURGE CURRENT

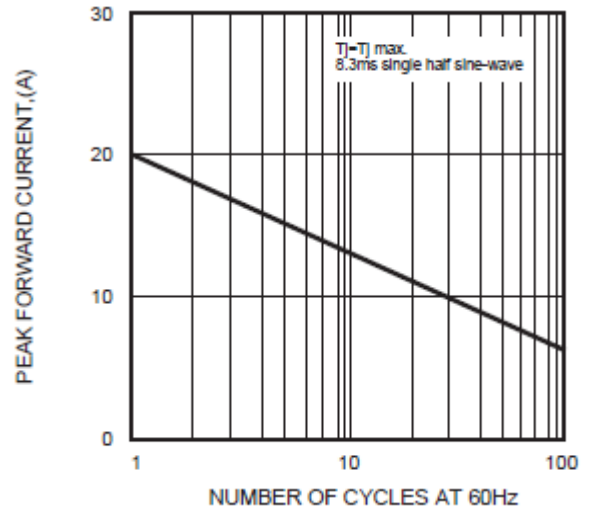

FIG.3 - STEADY STATE POWER DERATING CURVE

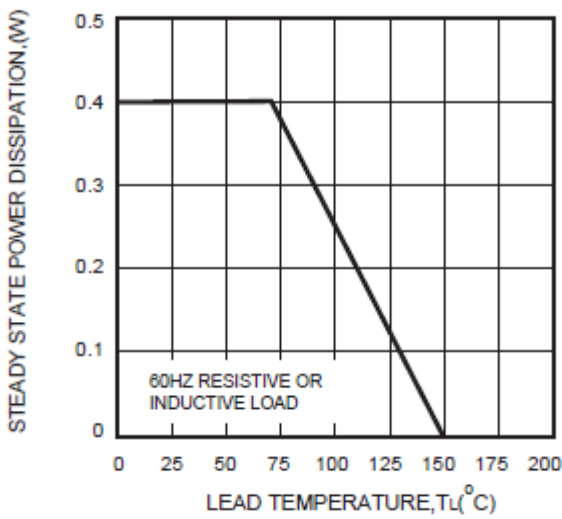

FIG.4- PEAK PULSE POWER RATING CURVE

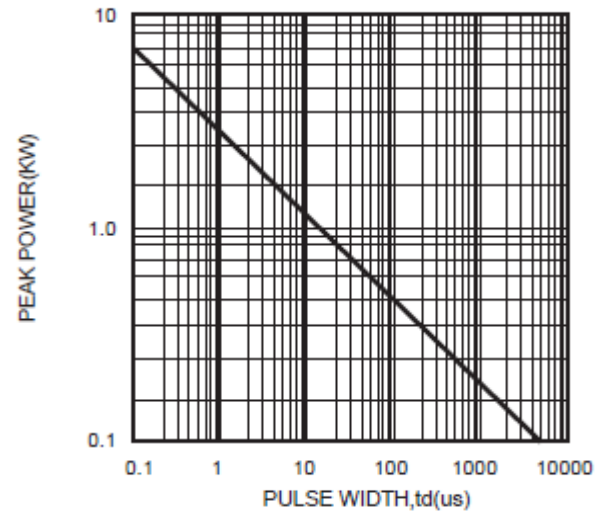

FIG.5 - PULSE WAVEFORM

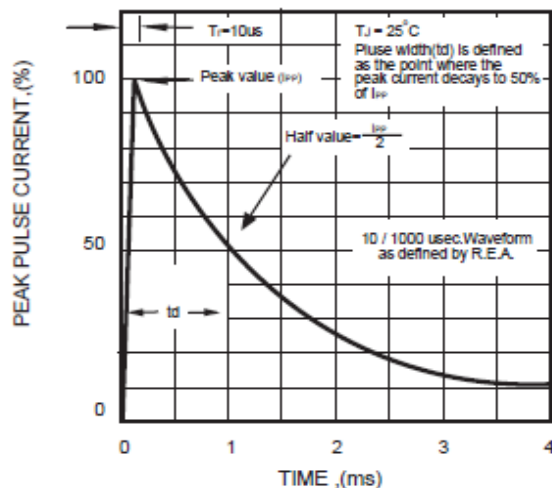
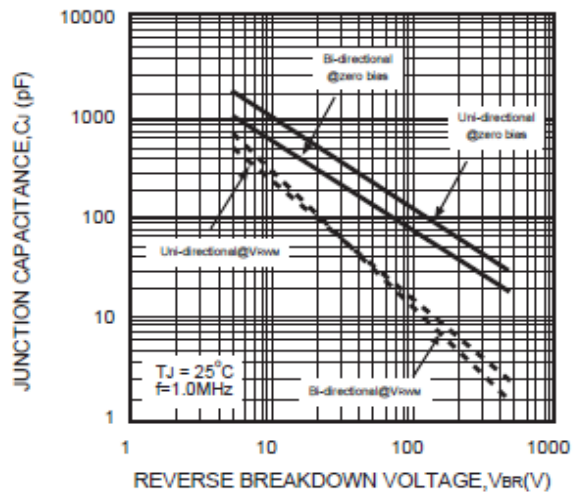

FIG.6 - TYPICAL JUNCTION CAPACITANCE



Transient Voltage Suppression Diodes: SMF Series

SMD Type 200 W



■ Soldering Recommendation

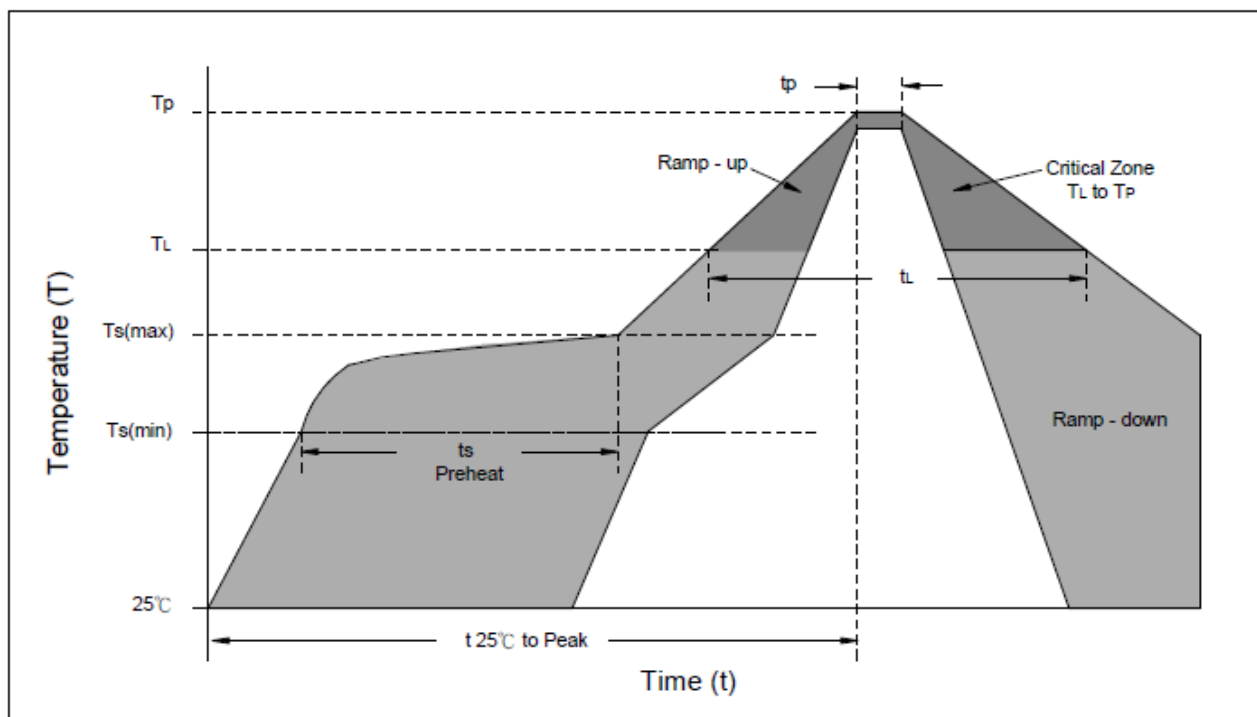

Reflow Condition	Lead-free assembly
Preheat -Temperature Min(Ts min) -Temperature Min(Ts max) -Time (min to max) (ts)	150°C 200°C 60 – 180 seconds
Average ramp up rate -Temperature Liquidus (TL) to peak	3°C/second max
Ts(max) to TL -Ramp-up Rate	3°C/second max.
Reflow -Temperature Liquidus (TL) -Time (tL)	217°C 60 – 150 seconds
Peak Temperature (TP)	260°C
Time within 5°C of actual peak Temperature(tp)	20 – 40 seconds
Ramp-down Rate	6°C/second max.
Time 25°C to peak Temperature(TP)	8 minutes max.
Do not exceed	260°C

Transient Voltage Suppression Diodes: SMF Series

SMD Type 200 W



■ Packaging

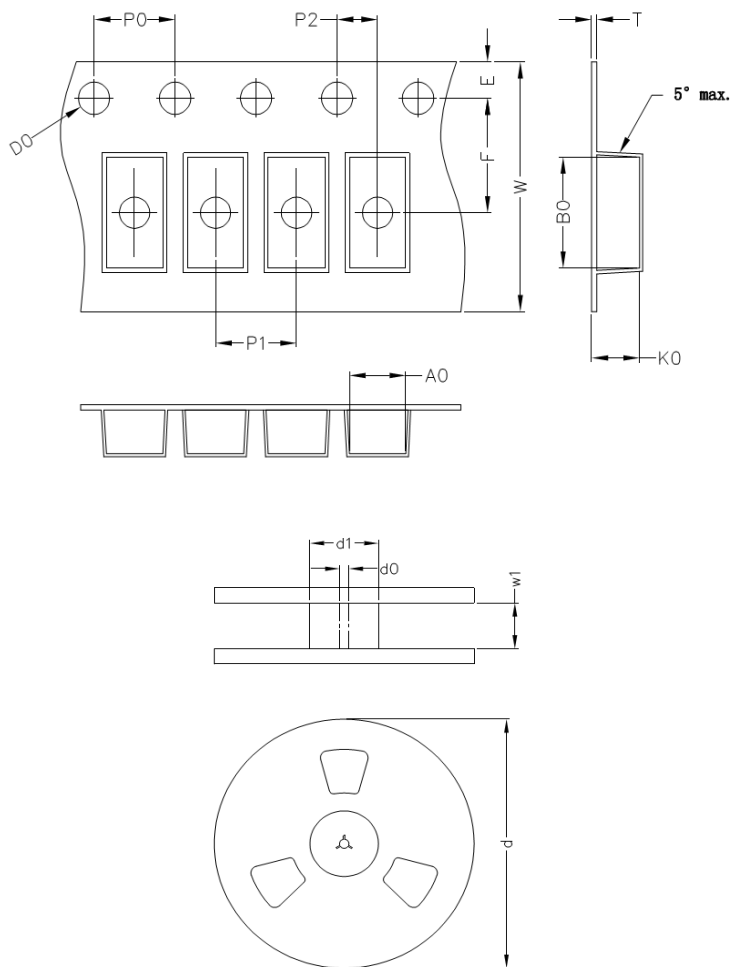

Item	Symbol	SOD-123S Unit: mm
Carrier width	A0	2.00
Carrier length	B0	3.95
Carrier depth	K0	1.45
Sprocket hole	D0	1.55
Sprocket hole position	E	1.75
Punch hole position	F	3.50
Sprocket hole pitch	P0	4.00
Carrier pitch	P1	4.00
Embossment center	P2	2.00
Tape thickness	T	0.23
Tape width	W	8.00
Reel outside diameter	d (7")	178.00
Reel inner diameter	d1	60.00
Feed hole diameter	d0	13.00
Reel inner width	w1	9.50

Note: The tolerance of carrier tape and top cover is ± 0.1 mm, and the tolerance of reel is ± 2 mm.

■ Quantity

MPQ: 3,000pcs

Package Type	Reel Size inch	Reel Kpcs	Inner Box Kpcs
SOD-123S	7	3	30

■ Warehouse Storage Conditions of Product

- Storage Condition:
 - Storage Temperature: $-10^{\circ}\text{C} \sim +40^{\circ}\text{C}$
 - Relative Humidity: $\leq 75\% \text{RH}$
 - Keep away from corrosive atmosphere and sunlight.
- Period of Storage: 1 year.